



Abbattitore di Temperatura
Blast chiller



Gelateria
Icecream



Ciclo conservazione
Conservation cycle



Scongelamento
Thawing



Programmi abbattimento
Chilling programs



Fermalievitazione
Retarder Prover



Cottura a bassa T°
Low Cooking T°



Ozono (opzionale)
Ozone (optional)

Caratteristiche

- Spessore isolamento pareti 70mm
- Costruito in AISI304
- Sbrinamento a Gas caldo e a ventilazione forzata
- Controllo Touch da 7"
- Funzioni presenti : Abbattimento positivo , negativo , continuo , abbattimento automatico, scongelamento, conservazione , fermalievita , cottura a bassa temperatura , ciclo gelato , programmi memorizzabili ,report allarmi HACCP
- Importazione ed esportazione dati con USB
- Algoritmo di controllo della umidificazione e deumidificazione
- Sonda prodotto

Opzioni

- Opzione kit ruote
- Opzione kit pasticceria passo 10 mm
- Condensazione ad acqua opzionale
- Sanitizzazione ad Ozono
- Versioni a 60 Hz
- Seconda sonda prodotto
- Connettività rete



Features

- Tickness insulation walls 70 mm
- AISI 304 stainless steel construction
- Hot gas defrosting and Forced ventilation
- 7" Touch control
- Functions available: Blast chilling, blast freezing, Blast freezing continuous, automatic blast chilling - thawing - ice cream- conservation- retarder provers - low temperature cooking - storable cycle programs - HACCP report alarms
- Upload and Download data with USB
- Humidification and dehumidification control algorithm
- Core (product) probe
- Castor kit option

Optional

- Castor kit
- Kit Pastry option step 10 mm
- Option Water condensing version
- Ozone sanitation
- 60Hz Versions
- Second core (product) probes
- Network connectivity

Capacità - Capacity



65 kg
+90°C → +3°C



50 kg
+90°C → -18°C

15

Teglie / Trays
GN 1/1
600x400 mm

21

Vaschette gelato
5 litres Pans
165x360xH120(mm)

68

PassoTeglie
Trays Pitch
(mm)

Caratteristiche - Features

Codice Prodotto Code number	BT15.65 A	BT15.65 W
Alimentazione Elettrica Power supply	400V/3N/50HZ	400V/3N/50HZ
Lunghezza esterna Outside length	840 mm	840 mm
Profondità Depth (con maniglia - with handle)	945 (995) mm	945 (995) mm
Altezza esterna Height (con ruote - with castors)	1952/ 2002 (1957) mm	1952/ 2002 (1957) mm
Capacità Capacity 600x400 GN 1/1 / litri - litres	15 / 330	15 / 330
Compressore Compressor	Semi-Hermetic	Semi-Hermetic
Resa abbattimento Output chilling (+90°C/+3°C) / (+90°C/-18°C)	65 Kg / 50 Kg	65 Kg / 50 Kg
Potenza riscaldamento Heating Power	1600 W	1600 W
Corrente assorbita/Consumo acqua Current absorbed / Water consumption	* 7.0 A 8.3 A	7.0 A / 198 l/h 8.3 A
Potenza frigorifera Refrigeration Power (-10°C/+45°C)	7800 W	7800 W
Tipo gas refrigerante / carica gas Refrigerant gas type / Gas charge	R452A (GWP 2141)/2200 g	R452A (GWP 2141)/2200 g
Livello rumore Noise level	68 dBA	68 dBA
Peso netto/lordo net/gross Weight	259 / 286 Kg	257 / 284 Kg
Dati spedizione (LxPxH) Shipment data (WxDxH)	880 x 1040 x 2160 mm 286 Kg	880 x 1040 x 2160 mm 284 Kg

Dimensioni - Dimensions

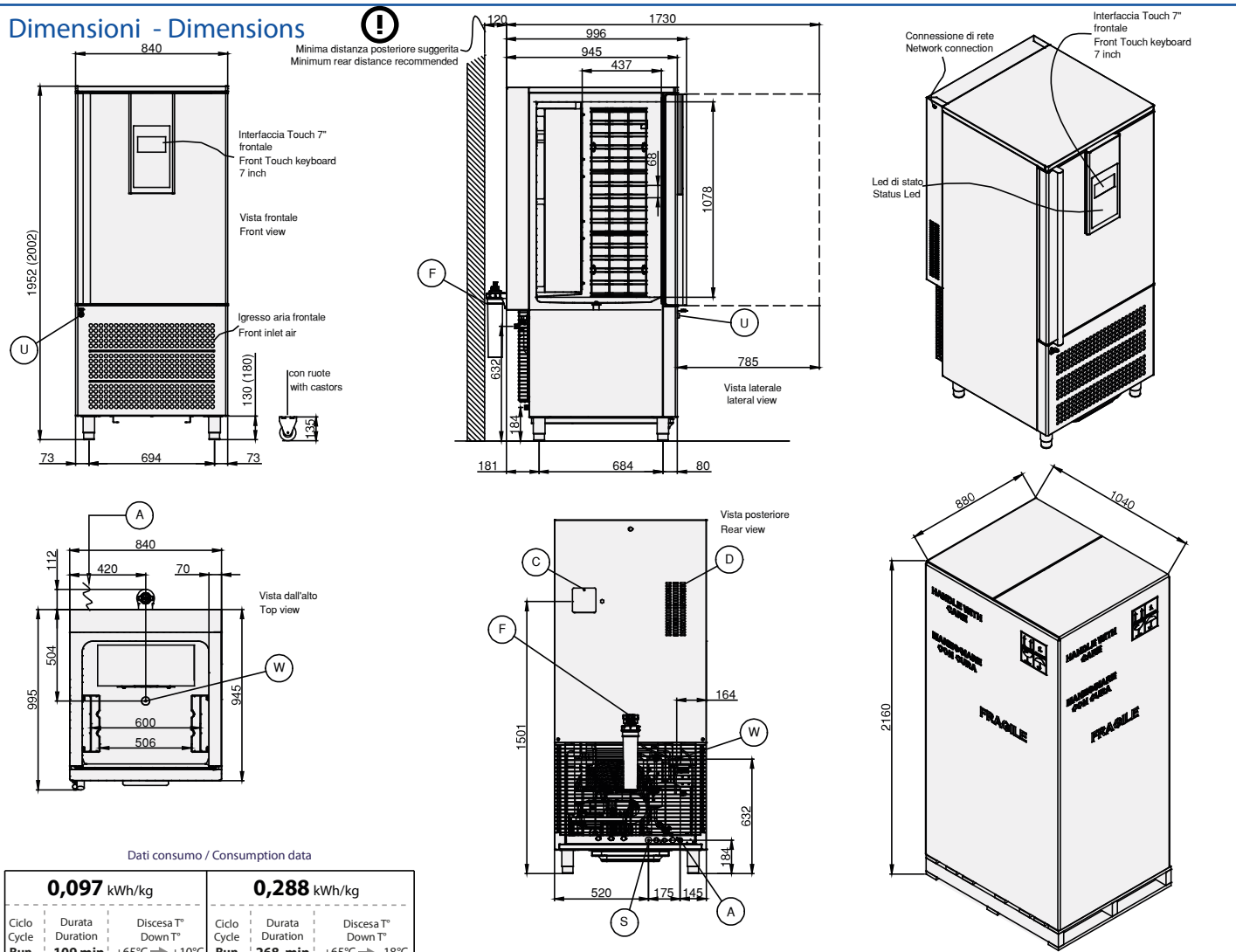

- (A) Electrical cable supply / Cavo Alimentazione
- (S) Water inlet connection 3/4" gas / Connessione ingresso acqua 3/4" gas
- (D) Dehumidification output / Uscita deumidificazione
- (F) Filtro acqua spruzzatori / Water sprayer filter
- (W) Drainage Discharge 20 mm / Scarico acqua 20 mm
- (C) Cleaning sprayer access / Accesso per pulizia spruzzatori
- (U) USB connection / Connessione USB

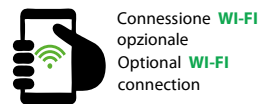

Funzioni / Functions

Versione / Version	Abbruttamento / Blast chiller cycles	Ciclo gelato / Ice cream cycle	Ciclo conservazione / Conservation cycle	Fermilievitazione / Retarder prover	Cottura a bassa T° / Low T° cooking	Ciclo scongelamento / Thawing cycles	Sbinamento gas caldo / Hot gas defrosting	Programmi memorizzati / Stored Programs	Ciclo Ozono / Ozone cycle	Ventil. Evaporatore a velocità variabile / Variable speed fans evaporator	Resistenza a potenza variabile / Variable power resistance	Controllo dinamico Set / Dynamic Frost Control	Algoritmo controllo umidità / Humidity control algorithm	Carico/Scarico dati-USB / Load/Download data-USB	Connettività rete / Network connectivity
START	●	●	●	●	●	●	●	●	●	●	●	●	●	●	●
FULL	●	●	●	●	●	●	●	●	●	●	●	●	●	●	●

INTERFACCIA 7" TOUCH / 7" TOUCH INTERFACE

